



The border of the page is decorated with various scientific symbols and formulas. At the top, there are two identical diagrams of a flask with a beaker on top, each with the formula $I_o = \frac{m_2}{r}$ next to it. Below these are two Bohr-style atomic models. Further down, there are two more identical flask-and-beaker diagrams, each with the formula $F_1(z) = \pi \cdot H^2$ next to it. On the right side, there is a $\log(x)$ formula. On the left side, there is a $\frac{1}{2} = e^{\pi^2} - e^{-\pi}$ formula. On the far left, there is a flask with the formula $\frac{1}{2} = e^{-\pi}$ next to it. On the far right, there is a flask with the formula $n = \frac{m}{r}$ next to it. At the bottom, there are several formulas including $V = \frac{m_i}{\rho}$, $k = \sqrt{(a+n)^2}$, $V = \pi r^2 h$, and $E = mc^2 - mv^2$. There are also several Bohr-style atomic models scattered throughout the border.

10TH STANDARD SCIENCE 1

QUESTION WISE PYQ

PRINT KAR AND STUDY KAR
SERIES 2026



10th Standard | Science 1 | Question wise PYQ

Print Kar and Study Kar _ Series 2026

For More Study Material Visit: www.saiphy.com

July 2025 | Q.1 (A) Choose the correct alternative: (1 Mark Each)

www.saiphy.com

Q.1. (A) Choose the correct alternative:

- i. Alkaline earth metals have valency 2. This means that their position in the modern periodic table is in _____.
(A) Group 2 (B) Group 16
(C) Period 2 (D) *d*-block
- ii. When the positive charge on an atom or an ion increases or the negative charge on them decreases it is called _____.
(A) Reduction (B) Oxidation
(C) Displacement (D) Decomposition
- iii. _____ device is used to produce electricity.
(A) Electric motor (B) Galvanometer
(C) Electric generator (D) Voltmeter
- iv. Light changes its direction when going from one transparent medium to another transparent medium. This is called the _____ of light.
(A) Reflection (B) Dispersion
(C) Refraction (D) Absorption
- v. Height of the High earth orbit from the surface of the earth is _____.
(A) = 20,000 km (B) = 27,000 km
(C) < 30,780 km (D) > 35,780 km

March 2025 | Q.1 (A) Choose the correct alternative: (1 Mark Each)

www.saiphy.com

Q.1. (A) Choose the correct alternative:

- i. Alkaline earth metals have valency 2. This means that their position in the modern periodic table is in _____.
(A) Group 2 (B) Group 16
(C) Period 2 (D) *d*-block
- ii. The reaction in which ions in the reactants are exchanged to _____ precipitate is called as _____ reaction.
(A) Combination (B) Decomposition
(C) Displacement (D) Double Displacement
- iii. _____ is used to make a solenoid type coil in an electric bulb.
(A) Nichrome (B) Copper
(C) Tisplacement (D) Aluminium
- iv. Light changes its direction when going from one transparent medium to another transparent medium. This process is called _____.
(A) Reflection (B) Dispersion
(C) Scattering (D) Refraction
- v. $\text{CaO} + \text{H}_2\text{O} \longrightarrow \text{Ca}(\text{OH})_2 + \text{Heat}$ is an example of _____ reaction.
(A) Exothermic (B) Electrolysis
(C) Decomposition (D) Endothermic

Q.1. (A) Write the correct alternative:

- i. The SI unit of heat is _____.
 (A) calorie (B) joule
 (C) kcal/kg °C (D) cal/g °C
- ii. We can see the sun even when it is little below the horizon because of _____.
 (A) Reflection of light (B) Refraction of light
 (C) Dispersion of light (D) Absorption of light
- iii. _____ is the functional group of carboxylic acid.
 (A) —COOH— (B) —CO—
 (C) —CHO— (D) —OH—
- iv. In simple microscope _____ lens is used.
 (A) Concave (B) Plano concave
 (C) Plano convex (D) Convex
- v. In _____ process a layer of molten tin is deposited on metals.
 (A) Anodization (B) Tinning
 (C) Galvanizing (D) Alloying

July 2023 | Q.1 (A) Choose the correct alternative: (1 Mark Each)

Q.1. (A) Choose the correct alternative and write the correct option:

- i. _____ has the highest refractive index.
 (A) Air (B) Water
 (C) Glass (D) Diamond
- ii. The left hand side of a chemical reaction represents _____.
 (A) Product (B) Reactants
 (C) Catalyst (D) Indicator
- iii. In _____ block of the modern periodic table non-metals are found.
 (A) s-block (B) d-block
 (C) p-block (D) f-block
- iv. The chemical reaction in which two or more products are formed from a single reactant is called _____ reaction.
 (A) Decomposition (B) Combination
 (C) Displacement (D) Double displacement
- v. If the refractive index of glass with respect to air is $\frac{3}{2}$, the refractive index of air with respect to glass is _____.
 (A) $\frac{1}{2}$ (B) 3
 (C) $\frac{1}{3}$ (D) $\frac{2}{3}$

Q.1. (A) Choose the correct alternative:

- i. The device used for producing current is called _____.
 (A) A voltmeter (B) An ammeter
 (C) A galvanometer (D) A generator
- ii. If a ray of light passes from a denser medium to a rarer medium in a straight line, the angle of incidence must be _____.
 (A) 0° (B) 30° (C) 60° (D) 90°
- iii. The power of convex lens of focal length 20 cm is _____.
 (A) +5.0 D (B) 0.20 D (C) -5.0 D (D) 0.5 D
- iv. Good conductor of electricity is _____.
 (A) Bromine (B) Iodine (C) Graphite (D) Sulphur
- v. The height of medium earth orbit above the surface of the earth is:
 (A) 1,500 km (B) 250 km (C) 45,000 km (D) 25,000 km

Q.1. (A) Choose the correct alternative and write the correct option:

- i. The formula for escape velocity is _____.
 (A) $\sqrt{\frac{2M}{R}}$ (B) $\sqrt{\frac{2GM}{R}}$
 (C) $\sqrt{\frac{GM}{R^2}}$ (D) $\sqrt{\frac{Gm}{R^2}}$
- ii. To prevent rusting, a layer of _____ metal is applied on iron sheets.
 (A) potassium (B) sodium
 (C) magnesium (D) zinc
- iii. Carbonate ores are strongly heated in a limited supply of air to transform them into oxides, this process is called _____.
 (A) leaching (B) calcination
 (C) roasting (D) tinning
- iv. For a particular value of 'i', the value of 'r' becomes equal to 90°. This value of 'i' is called the _____.
 (A) critical angle (B) angle of deviation
 (C) angle of refraction (D) angle of emergence
- v. The _____ controls the amount of light entering the eye.
 (A) iris (B) pupil
 (C) cornea (D) retina

For More Such Study Material for standard 10th

Keep Visiting www.saiphy.com

If any of the study material is helpful for you

Kindly Send your review on

9664080155

Easy Notes By Sai Sir

Q.1. (A) Choose the correct Alternative:

- i. Gold plated ornaments is the example of _____.
 (A) Electroplating (B) Alloying
 (C) Anodizing (D) Galvanizing
- ii. The functioning of the satellite launch vehicle is based on _____.
 (A) Newton's first law of motion (B) Newton's second law of motion
 (C) Newton's third law of motion (D) Newton's universal law of gravitation
- iii. _____ is one of the combustible components of L.P.G.
 (A) Ethane (B) Propane
 (C) Methane (D) Ethene
- iv. The power of a convex lens of focal length 25 cm is _____.
 (A) 4.0 D (B) 0.25 D (C) -4.0 D (D) -0.4 D
- v. _____ colour is deviated the least, in the spectrum of white light obtained with a glass prism.
 (A) Red (B) Yellow (C) Violet (D) Blue

Q.1. (A) Choose the correct option:

- i. The minimum velocity of the spacecraft to escape from earth's gravitational force must be _____.
 (A) 112 km/s (B) 11.2 km/s (C) 1.12 km/s (D) 0.112 km/s
- ii. The melting point of pure ethanoic acid is _____.
 (A) 17°C (B) 19°C (C) 15°C (D) 27°C
- iii. The process of separation of light into its component colour while it is passing through a medium is called _____.
 (A) Reflection (B) Refraction
 (C) Dispersion (D) Internal reflection
- iv. The conversion of ferrous sulphate into ferric sulphate is _____ reaction.
 (A) Oxidation (B) Displacement
 (C) Electrolysis (D) Reduction
- v. Lithium (Li), _____ and Potassium (K) is Dobereiner's triad.
 (A) Magnesium (Mg) (B) Aluminium (Al)
 (C) Sodium (Na) (D) Calcium (Ca)

Q.1. (A) Write the correct alternative:

- i. According to Mendeleev's periodic law, properties of elements are periodic function of their _____.
 (A) Atomic numbers (B) Atomic masses
 (C) Densities (D) Boiling points
- ii. The vapour content in the air is measured using a physical quantity called _____.
 (A) Absolute humidity (B) Relative humidity
 (C) Dew point (D) Humidity
- iii. For the normal human eye, the near point is at _____ cm.
 (A) 10 (B) 20 (C) 25 (D) 30
- iv. The astronomical object closest to us is _____ is our galaxy.
 (A) Mars (B) Venus (C) Jupiter (D) Moon
- v. In the Wilfley table method, the particles of gangue are separated by _____ separation method.
 (A) Magnetic (B) Froth floatation (C) Hydraulic (D) Gravitational

(B) Choose the correct alternative and rewrite the statement:

- i. Combustion of coal in air is a _____ reaction.

(A) combination	(B) displacement
(C) decomposition	(D) double displacement

- ii. When electric current is passed through the solenoid, it shows magnetic lines of force similar to a _____.

(A) bar magnet	(B) horse shoe magnet
(C) disk magnet	(D) spherical magnet

- iii. The crystals of ferrous sulphate are _____.

(A) Blue in colour	(B) Pink in colour
(C) Pale green in colour	(D) Colourless

- iv. A laser beam enters from air to soap solution in water then _____.

(A) it goes away from the normal	(B) it bends towards the normal
(C) it travels straight without bending	(D) it returns back into air

- v. When temperature of water is reduced below _____ °C, it expands.

(A) 0	(B) 4	(C) 5	(D) 12
-------	-------	-------	--------

March 2019 | Q.1 (A) Choose the correct alternative: (1 Mark Each)

(B) Choose the correct alternative:

1. The reaction of iron nail with copper sulphate solution is _____ reaction.

(A) Combination	(B) Decomposition
(C) Displacement	(D) Double displacement

2. Observe the following diagram and choose the correct alternative:

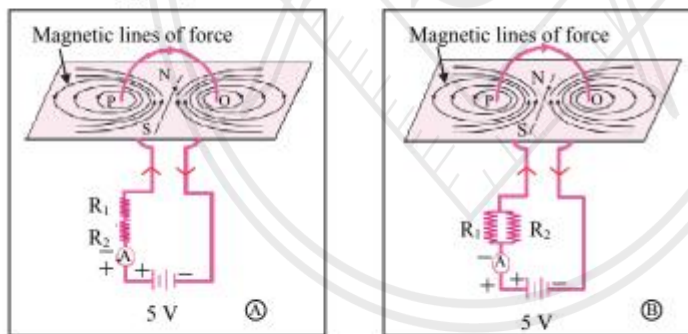

- | | |
|---|---|
| (A) The intensity of magnetic field in A is larger than in B. | (B) The intensity of magnetic field in B is less than in A. |
| (C) The intensity of magnetic field in A and B is same. | (D) The intensity of magnetic field in A is less than in B. |
3. A ray of light makes an angle of 50° with the surface S_1 of the glass slab. Its angle of incidence will be _____.

(A) 50°	(B) 40°
(C) 140°	(D) 0°

 4. Water expands on reducing its temperature below _____ °C.

(A) 0	(B) 4
(C) 8	(D) 12

 5. The carbon compound is used in daily life is _____.

(A) Edible oil	(B) Salt
(C) Carbon dioxide	(D) Baking soda

(B) Answer the following questions:

- i. Find the odd one out:
Fuse wire, bad conductor, rubber gloves, generator.
- ii. Complete the co-relation.
Red light wavelength close to : 700 nm :: Violet light wavelength close to : _____.
- iii. Match the pair:

Group 'A'		Group 'B'
Farsightedness	a.	Faraway object can be seen clearly
	b.	Nearby object can be seen clearly
	c.	Faraway object cannot be seen clearly

- iv. Write the electronic configuration of 'Aluminium'.
- v. State true or false:
The escape velocity on the moon is less than that on the earth.

March 2025 | Q.1 (B) Answer the following question: (1 Mark Each)

www.saiphy.com

(B) Answer the following questions:

- i. State whether true or false:
A redox reaction takes place during cellular respiration.
- ii. Find the odd one out:
Loudspeaker, microphone, electric motor, magnet.
- iii. What is the reason for twinkling of stars?
- iv. Match the columns:

Column 'A'		Column 'B'
Simple microscope	a.	used to observe minute objects
	b.	used to see distant objects
	c.	used for watch repair

- v. Name the behaviour of water between its temperature from 0°C to 4°C.

For More Such Study Material for standard 10th

Keep Visiting www.saiphy.com

If any of the study material is helpful for you

Kindly Send your review on

9664080155

Easy Notes By Sai Sir

(B) Answer the following:

- i. Write the name of the atom having the smallest size.
- ii. Write the molecular formula of calcium carbonate.
- iii. Write the use of 'Calorimeter'.
- iv. Identify the hydrocarbon from the given electron-dot structure :

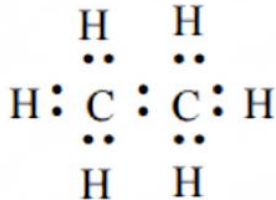

- v. Match the columns:

Column 'A'		Column 'B'
Refractive index of water	(a)	1.31
	(b)	1.36
	(c)	1.33

(B) Attempt the following questions:

- i. State whether the given statement is true or false:
Rancidity is oxidation process.
- ii. Find the odd man out:
Camera, Telescope, Peephole in door, Microscope
- iii. Find the co-relation:
Resistance : Ohm :: Potential difference : _____
- iv. Write the defect of eye from the given figure:

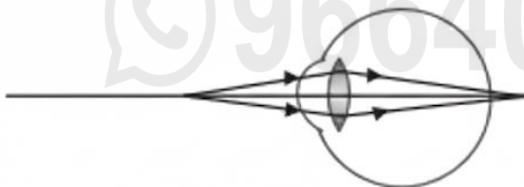

- v. Give the unit of intensity of magnetic field.

(B) Answer the following questions:

- i. Find the odd man out:
Loudspeaker, Microphone, Electric motor, Magnet.
- ii. Complete the co-relation:
 CuI_2 : Brown : : AgCl : _____
- iii. Match the pair:

Group 'A' Substance	Group 'B' Refractive index
Air	(a) 1.33
	(b) 1.46
	(c) 1.0003

- iv. State True *or* False:
"Wavelength of red light is close to 700 nm."
- v. Write the name of small satellite made by a group of students from COEP (College of Engineering, Pune) sent to the space through ISRO in 2016.

July 2022 Q.1 (B) Answer the following question: (1 Mark Each)

(B) Answer the following

- i. Match the correct pair:

Column 'A'		Column 'B'
Electric	a.	The ohm
	b.	The ampere
	c.	The volt

- ii. What is the height of the low earth orbit satellite above the earth's surface?
- iii. State true or false :
When the incident ray is parallel to the principal axis, the refracted ray does not pass through the principal focus.
- iv. Find the odd man out :
Methane, Ethene, Propane, Butane:
- v. Identify the law from the given figure :



For More Such Study Material for standard 10th

Keep Visiting www.saiphy.com

If any of the study material is helpful for you

Kindly Send your review on

9664080155

Easy Notes By Sai Sir

(B) Answer the following:

- i. Find the odd one out:
INSAT, GSAT, IRS, PSLV
- ii. Complete the correlation:
Group 1 : Alkali metals :: _____ : Halogens.
- iii. Match the correct pair:

Column 'A'	Column 'B'
Refractive index of water	(a) 1.31
	(b) 1.36
	(c) 1.33

- iv. State True or False:
An electric motor converts mechanical energy into electrical energy.
- v. Write the IUPAC name for the following structural formula:

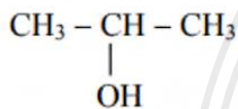

December 2020 Q.1 (B) Answer the following question: (1 Mark Each)

(B) Solve the following sub-questions:

- . State true *or* false:
The refractive index depends upon the velocity of light in medium.
- i. Write the correlated answer:
Torch : Concave lens :: Camera : _____.
- ii. Find odd man out:
Zinc, Iron, Phosphorus, Sodium.
- v. Draw the structural formula of C₃H₈.
- /. Which satellite is used in educational field among INSAT and GSAT series?

March 2020 Q.1 (B) Answer the following question: (1 Mark Each)

(B) Answer the following:

- i. Find the odd one out:
Voltmeter, Ammeter, Thermometer, Galvanometer.
- ii. Complete the correlation:
Alkene : C = C :: Alkyne: _____.
- iii. State true or false:
The frequency of AC is 50 Hz.
- iv. Match the Columns:

Column 'A'	Column 'B'
The wavelength of red light	(a) 600 nm
	(b) 700 nm
	(c) 500 nm

- v. Name the first artificial satellite sent by Russia in space.

- i. Fill in the blank and rewrite the sentence:
The initial velocity (during launching) of the Mangal-Yaan must be greater than _____ of the earth.

- ii. Match the pairs:

	Group 'A'		Group 'B'
i.	Ethanol	a.	Hydrogen peroxide
ii.	Methane	b.	Tincture iodine
		c.	Biogas
		d.	Non-stick cookware

- iii. Write co-relation:
Molecular formula of beryllium oxide: BeO :: Molecular formula of beryllium chloride : _____
- iv. Write whether the following statement is true or false:
Simple microscope is used for watch repairs.

March 2019 Q.1 (B) Answer the following question: (1 Mark Each)

1. Write proper answer in the box:



If $F = \frac{Gm_1m_2}{d^2}$,

then $F =$

2. In Dobereiner's triads Li, Na, K, the atomic masses of Lithium and Potassium are 6.9 and 39.1 respectively, then what will be the atomic mass of sodium.
3. State whether the given statement is true or false:
A concave lens is a converging lens.
4. By considering first correlation complete the second correlation:
Hubble telescope: 569 km high from earth surface
Revolving orbit of Hubble telescope:
5. Find the odd man out:
Tinning, Anodization, Alloying, Froth floatation.

For More Such Study Material for standard 10th

Keep Visiting www.saiphy.com

If any of the study material is helpful for you

Kindly Send your review on

9664080155

Easy Notes By Sai Sir

Q.2. (A) Give scientific reasons (any two):

- i. Sodium is always kept in kerosene.
- ii. We cannot clearly see an object kept at a distance less than 25 cm from the eye.
- iii. Tungsten metal is used to make a solenoid type coil in an electric bulb.

Q.2. (A) Give scientific reasons (any two):

- i. While going from left to right within a period, the size of atom decreases.
- ii. For electric power transmission, copper or aluminium wire is used.
- iii. In some countries, ethanol is used as an additive to increase the efficiency of petrol.

Q.2. (A) Give scientific reasons (any two):

- i. When the gas formed on heating limestone, is passed through freshly prepared lime water, the lime water turns milky.
- ii. Tungsten metal is used to make a solenoid type coil in an electric bulb.
- iii. On exposure to air, silver articles turn blackish after some time.

Q.2. (A) Give scientific reasons (any two):

- i. Tungsten metal is used to make solenoid type coil in an electric bulb.
- ii. Simple microscope is used for watch repairs.
- iii. Metallic character goes on decreasing while going from left to right in a period.

Q.2. (A) Give scientific reasons (any two):

- i. For electric power transmission, copper or aluminium wire is used.
- ii. Lemon or tamarind is used for cleaning copper vessels turned greenish.
- iii. Elements belonging to the same group have the same valency.

Q.2. (A) Give scientific reasons (any two):

- i. Generally, most of the carbon compounds are bad conductors of electricity.
- ii. A magnetic needle shows decreasing deviation of its angle as distance from a current conductor is increased.
- iii. We see the sun even before it emerges above the horizon.

Q.2. (A) Give scientific reasons (any two):

- i. Atomic radius goes on increasing down a group.
- ii. Simple microscope is used for watch repairs.
- iii. It is recommended to use airtight container for storing oil for long time.

Q.2. (A) Give scientific reasons (any two):

- i. Star appears to be twinkling at night.
- ii. Simple microscope is used for watch repairs.
- iii. The copper vessels turn greenish and silver articles turn blackish when kept open in air for long time.

Q.2. (A) Give scientific reasons (any two):

- i. The weight of an object changes from place to place though its mass is constant.
- ii. Stars twinkle but we do not see the twinkling of planets.
- iii. Elements belonging to the same group have the same valency.

July 2019 Q.2 Answer the following questions

- i. If mass of a planet is eight times the mass of the earth and its radius is twice the radius of the earth, what will be the ratio of escape velocity of earth to the escape velocity on the planet?
- ii. Explain why value of g changes if we go inside the earth.
- iii. Complete the following flowchart and write the general formula of alkane:



- iv. What is a geostationary satellite? Why are geostationary satellites not useful for studies of polar region?
- v. If the speed of light in a medium is 1.5×10^8 m/s, what is the absolute refractive index of the medium? (Velocity of light in vacuum 3×10^8 m/s)
- vi. In two methods of control of corrosion of aluminium, either a layer of aluminium oxide is formed or a silver plating is done on the surface. State to which electrode the aluminium article is attached in these methods respectively.
- vii. Write down any two rules used for drawing ray diagrams for the formation of image by convex lens.

March 2019 Q.2 Answer the following questions

1. Two tungsten bulbs of power 50 W and 60 W work on 220 V potential difference. If they are connected in parallel, how much current will flow in the main conductor?
2. Give scientific reason:
In the electric equipment producing heat e.g. iron, electric heater, boiler, toaster etc., an alloy such as Nichrome is used, not pure metals.
3. A metal ball of mass 5 kg falls from a height of 490 m. How much time it will take to reach the ground? ($g = 9.8 \text{ m/s}^2$)
4. Write names of first four homologous series of alcohols:

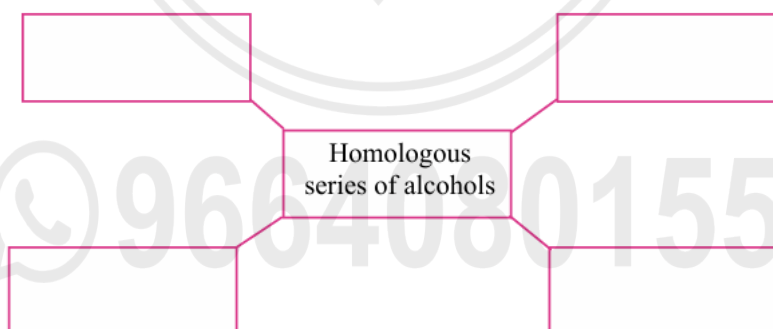

5. Observe the following figure and complete the table:

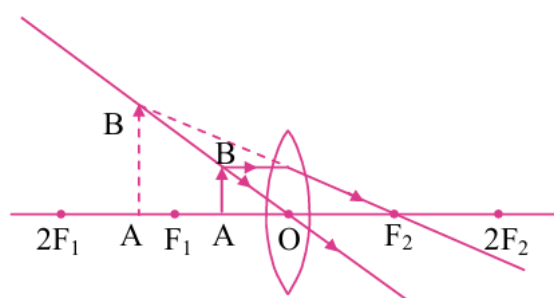

	Points	Answers
i.	Position of the object	
ii.	Position of the image	
iii.	Size of the image	
iv.	Nature of the image	

6. Out of sodium and sulfur which is a metal? Explain its reaction with the oxygen.
7. A tapping vessel opens in a tank like container that is tapering on the lower side. The tank has an outlet for water on the upper side and a water inlet on the lower side. Finely ground ore is released in the tank. A forceful jet of water is introduced in the tank from lower side and gangue particles and pure ore are separated by this method.
- The above description is of which gravitation separation method?
 - Draw labelled diagram of this method.



 9664080155

For More Such Study Material for standard 10th

Keep Visiting www.saiphy.com

If any of the study material is helpful for you

Kindly Send your review on

9664080155

Easy Notes By Sai Sir

(B) Answer the following questions (any three):

- i. An object takes 5 seconds to reach the ground from a height of 5 m on a planet. What is the value of 'g' on the planet?
- ii. An element has its electronic configuration as 2, 8, 2. Now answer the following questions:
 - a. What is the atomic number of this element?
 - b. To which period does this element belong?
- iii. Complete the following reaction and give name of products:

$$\text{CuSO}_{4(\text{aq})} + \text{Fe}_{(\text{s})} \longrightarrow \text{_____} + \text{_____}$$
- iv. Define specific heat of an object. Write its SI and CGS units.
- v. Draw the electron-dot structure of methane (CH_4) and Ethane (C_2H_6).

March 2025 Q.2 (B) Answer the following questions**(B) Answer the following (any three):**

- i. Name and state the principle used to measure the specific heat capacity of a substance.
- ii. What is done to prevent rusting of iron door of your house?
- iii. Distinguish between mass and weight.
- iv. The 'rocket' is a type of fire cracker used in Diwali.
 - (a) Name the launcher.
 - (b) Name the law on which its working is based.
- v. What is meant by decomposition reaction? Write the chemical reaction of decomposition of sugar on heating.

March 2024 Q.2 (B) Answer the following questions**(B) Answer the following (any three):**

- i. State Dobereiner's law of triad. Give *one* example of it.
- ii. Identify the figure and explain its use:

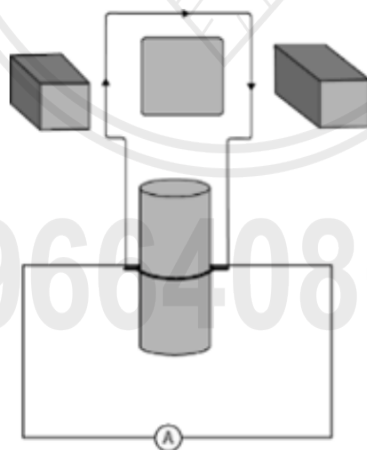

- iii. What is meant by satellite launch vehicle? Name any one Indian satellite launch vehicle.
- iv. What is free fall? When is it possible?
- v. The focal length of a convex lens is 20 cm. What is its power?

(B) Answer any three of the following questions:

i. Write the IUPAC names of the following structural formulae:

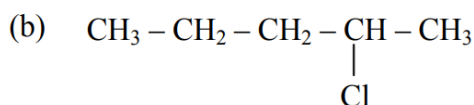
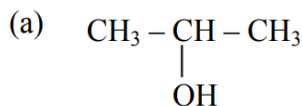
ii. An iron ball of mass 5 kg is released from a height of 125 m and falls freely to the ground. Assuming that the value of g is 10 m/s^2 , calculate time taken by the ball to reach the ground.

iii. What is meant by artificial satellite? Name the first satellite launched by Russia

iv. Draw the image formed by convex lens, if object is placed at $2F_1$.

v. Why does the apparent position of stars keep changing a bit?

March 2023 Q.2 (B) Answer the following questions**(B) Answer the following questions (any three):**

i. How do we feel about air in each of the following conditions?

(a) Relative humidity is more than 60%.

(b) Relative humidity is less than 60%.

ii. Complete the following reaction:



iii. Distinguish between Mass and Weight.

iv. Complete the following table:

Type of Satellite		The names of Indian Satellite and launcher
1.	Navigational Satellite	Satellite : _____ Launcher : _____
2.	Earth observation Satellite	Satellite : _____ Launcher : _____

v. Define periods and groups of modern periodic table.

July 2022 Q.2 (B) Answer the following questions**(B) Answer any three of the following questions:**i. How much heat energy is necessary to raise the temperature of 10 kg of water from 30°C to 100°C ?(Specific heat capacity of water (c) = $1 \text{ kcal/kg} \cdot ^\circ\text{C}$)ii. Will the value of g be the same everywhere on the surface of the earth? Justify your answer.

iii. Identify the exothermic and endothermic reactions :

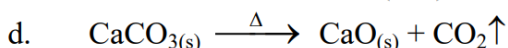
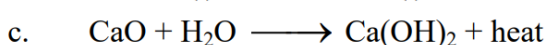
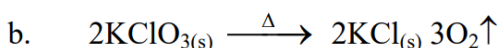
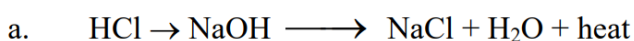

iv. Give one function of each of the following satellites:

a. Communication satellite

b. Earth observation satellite

v. State any two uses of ethanol.

(B) Answer the following questions (any three):

- i. An object takes 5 s to reach the ground from a height of 5 m on a planet. What is the value of 'g' on the planet?
- ii. Draw a neat labelled diagram of Hope's Apparatus.
- iii. State the Laws of Refraction.
- iv. Answer the following:
 - (a) Name the main ore of aluminium.
 - (b) What impurities are present in aluminium ore?
- v. Observe the given figure of Fleming's Left Hand Rule and write the labels of 'A' and 'B':

Force of the conductor

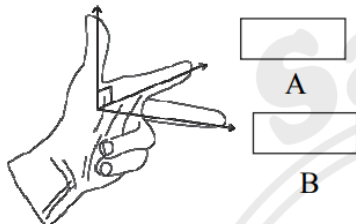

December 2020 Q.2 (B) Answer the following questions

(B) Answer the following questions (any three):

- i. An object takes 5 seconds to reach the ground from a height of 5 m on a planet. What is the value of 'g' on that planet?
- ii. Identify 'A' and 'B' from the following table and complete the table. Write the chemical equation:

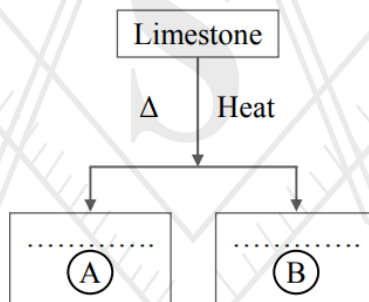

- iii. Write the modern periodic law and also give the names of 'blocks' in modern periodic table.
- iv. Distinguish between 'alternating current' and 'direct current'.
- v. Define specific heat capacity. Write its S.I. unit.

March 2020 Q.2 (B) Answer the following questions

(B) Answer the following (any three):

- i. How much heat energy is necessary to raise the temperature of 5 kg of water from 20°C to 100°C?
- ii. Observe the given figure of Fleming's Right Hand Rule and write the labels of A and B correctly.

Motion of a conductor

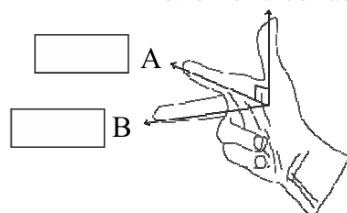

iii. Observe the given graph and answer the following questions:

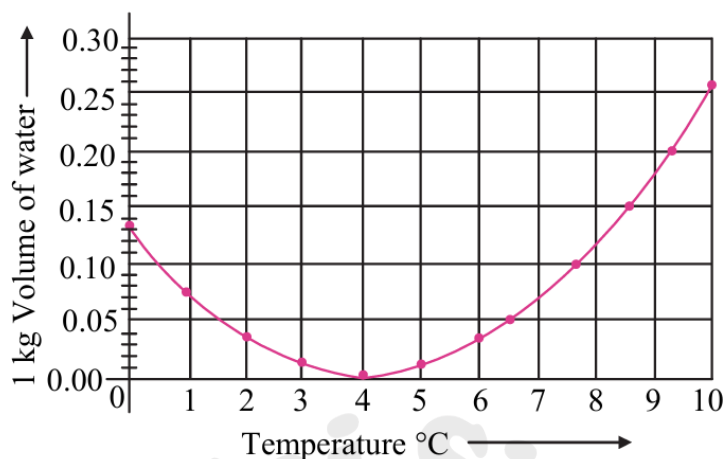

- a. Name the process represented in the figure.
 - b. At what temperature does this process take place?
- iv. Complete the given chemical reaction:
 $\text{CuSO}_4 (\text{aq}) + \text{Fe} (\text{s}) \rightarrow \underline{\hspace{2cm}} + \underline{\hspace{2cm}}.$
Name the type of the reaction.
- v. Write a short note on Alloying.

July 2019
No Questions for Q.2B

March 2019
No Questions for Q.2B

9664080155

For More Such Study Material for standard 10th

Keep Visiting www.saiphy.com

If any of the study material is helpful for you

Kindly Send your review on

9664080155

Easy Notes By Sai Sir

Q.3. Answer the following questions (any five):

- i. Explain the concept 'escape velocity' in detail.
- ii. Answer the following sub-questions regarding the modern periodic table:
 - a. Write modern periodic law.
 - b. Write the number of periods and groups.
 - c. What is the valency of halogens?
- iii. State whether the following reactions are endothermic or exothermic:
 - a. $\text{HCl} + \text{NaOH} \longrightarrow \text{NaCl} + \text{H}_2\text{O} + \text{Heat}$
 - b. $2\text{KClO}_{3(s)} \xrightarrow{\Delta} 2\text{KCl}_{(s)} + 3\text{O}_2 \uparrow$
 - c. $\text{CaO} + \text{H}_2\text{O} \longrightarrow \text{Ca(OH)}_2 + \text{Heat}$
- iv. Identify figure and write *one* use of it:

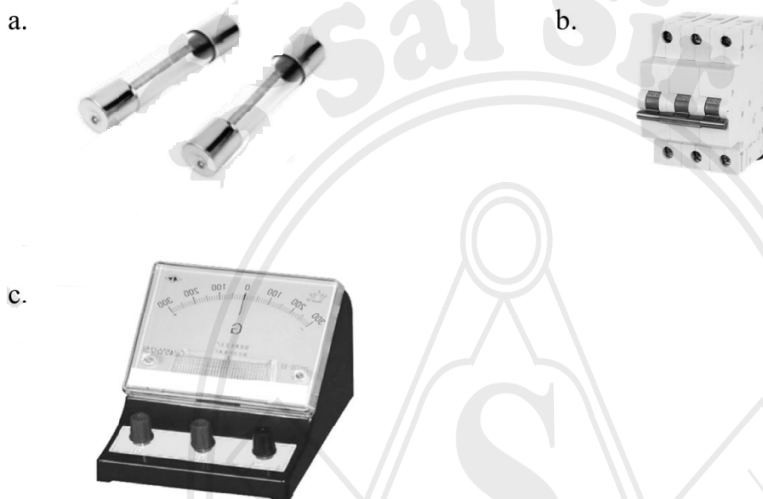

- v. How much heat energy is necessary to raise the temperature of 5 kg of water from 20°C to 100°C ?
[c = 1 kcal/kg°C]
- vi. Write the Cartesian sign convention for lenses.
- vii. Complete the following chart:

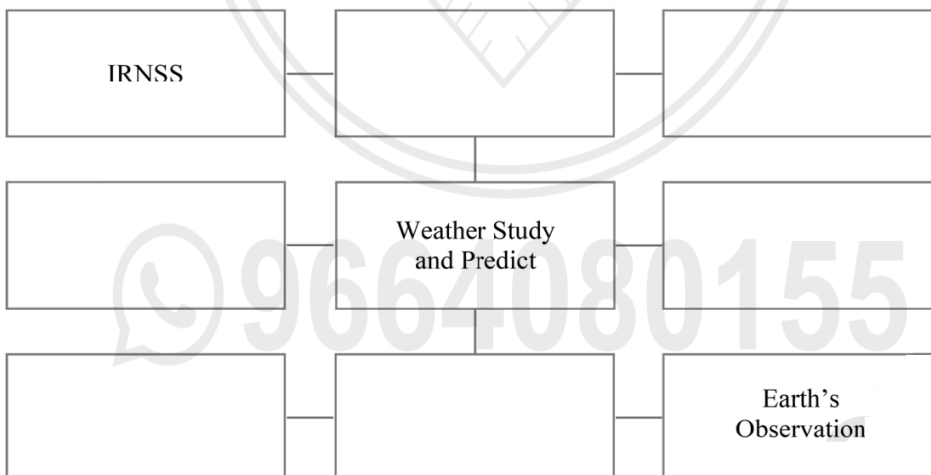

- viii. Give the chemical equations for the following reactions:
 - a. Thermit reaction
 - b. Burning of magnesium in air
 - c. Iron nail/dust is dropped in aqueous solution of copper sulphate.

Q.3. Answer the following questions (any five):

- i. An iron ball of mass 3 kg is released from a height of 125 m and falls freely to the ground. Assuming that the value of g is 10 m/s^2 , calculate:
 - (a) Time taken by the ball to reach the ground.
 - (b) Velocity of the ball on reaching the ground.
- ii. Write the name and symbol of the element from the description:
 - (a) The most electronegative atom.
 - (b) The atom having smallest atomic mass.
 - (c) The noble gas with the smallest atomic radius.
- iii.
 - (a) What happens when copper reacts with concentrated nitric acid? What is the colour of the gas released during the reaction?
 - (b) Write its balanced chemical equation.
 - (c) Write the names of reactants and products.
- iv. Name the following diagrams and explain the concept behind them:

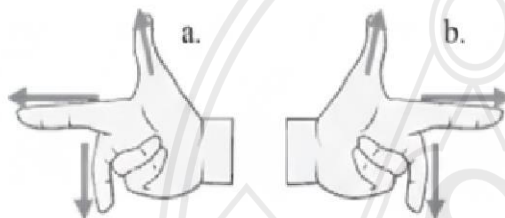

- v. Answer the following
 - (a) Draw a neat diagram to show the formation of rainbow.
 - (b) Name any two natural processes involved in formation of rainbow.
 - (c) What does a small droplet of water act as?
- vi. Name the following:
 - (a) The two metals which can be cut with knife.
 - (b) A sound is produced when certain metals are struck. Name this property of metals.
 - (c) The non-metallic substance which is a good conductor of electricity.
- vii. Answer the following questions with the help of the given diagram:

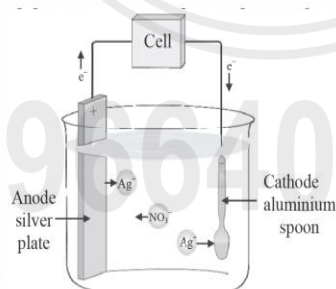

- (a) Name the process shown in the diagram.
 - (b) How does this process take place?
 - (c) Give two examples in which this process is used.
- viii. Complete the following table:

	Type of the satellite	Function of the satellite	The names of the Indian satellite series and their launch vehicles
(a)	_____	Fix the location of any place on the earth's surface	_____
(b)	Weather satellite	_____	_____
(c)	_____	_____	IRS Launcher: PSLV

Q.3. Answer the following questions (any five):

- i. Select the appropriate option and complete the following paragraph :
(Metals, non-metals, metalloids, four, seven, s-block, p-block, d-block, f-block.)
On the basis of electronic configuration, elements in the modern periodic table are classified into _____ blocks. Group 1 and 2 elements are included in _____ and all these elements are metals. (except hydrogen). Group 13 to 18 elements are included in _____. This block contains metals, non-metals and metalloids. Group 3 to 12 elements are included in _____ and all the elements are _____ elements shown at the bottoms of the periodic table i.e., lanthanides and actinides constitute _____ and all these elements are metals.
- ii. (a) What are the factors affecting the rate of chemical reaction?
(b) Explain any *one* factor.
- iii. Observe the following graph answer the following questions.

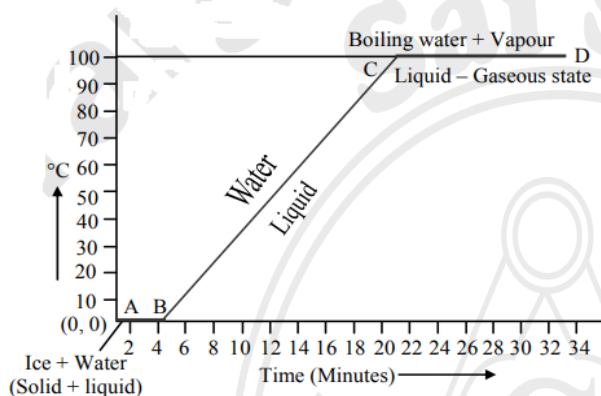

- (a) What does the graph represent?
- (b) What does the line AB represent?
- (c) What does the line BC represent?
- iv. Complete the following table by observing the given figures:

Points ↓	Figure		
	→		
(a)	Name of the defect	_____	_____
(b)	Position of the image	_____	_____
(c)	Lens used to correct the defect.	_____	_____

- v. Write any *three* general properties of ionic compounds.
- vi. Observe the figure and answer the questions:
 - (a) State Newton's universal law of gravitation.
 - (b) If the distance between the two bodies is tripled, how will the gravitational force between them change?
 - (c) What will happen to gravitational force, if mass of one of the objects is doubled?
- vii. The orbit of a satellite is exactly 35780 km above the Earth's surface and its tangential velocity is 3.08 km/s.
How much time the satellite will take to complete one revolution around the earth?
(Radius of the Earth = 6400 km.)
- viii. What is a solenoid? Draw a neat diagram and name its various components.

Q.3. Answer any five of the following questions:

- i. Identify the process given below and accordingly draw neat labelled diagram:
A molten mixture of alumina (melting point > 2000°C) is done in a steel tank. The tank has a graphite lining on the inner side. The lining does the work of cathode. A set of graphite rods dipped in the molten electrolyte works as anode. Cryolite (Na₃AlF₆) and fluorspar (CaF₂) are added in the mixture to lower its melting point upto 1000°C.
- ii. With reference to the given diagram answer the following questions:

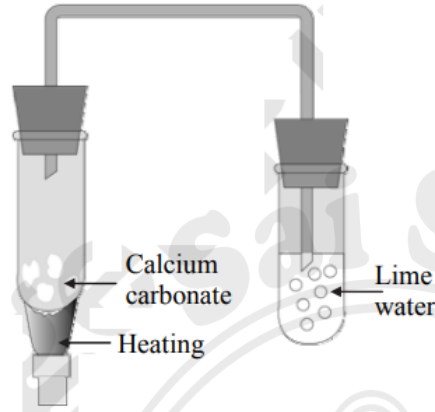

- (a) Give type of chemical reaction.
 - (b) Give the names of reactants and products.
 - (c) Write down the balanced chemical equation.
- iii. What is Electrical Power? Derive the unit of electric power from the given equations:

$$P = V \times \square$$

$$P = \square \times \text{ampere}$$

$$= 1 \text{ volt} \times 1 \square = \frac{1\text{J}}{1\text{C}} \times \frac{1\text{C}}{1\text{S}}$$

$$\therefore P = \frac{1\text{J}}{\square} = \text{W (Watt)}.$$

- iv. Explain the term anodization with example. Give *one* use of it.
- v. State Kepler's *three* laws of motion.
- vi. The electronic configuration of an element X is 2, 8, 8, 2.
 - (a) What is the atomic number of the element X?
 - (b) To which group does this element belong?
 - (c) In which period does this element lie?
- vii. What is the contribution of India in space technology?
- viii. Observe the given diagram and answer the following questions:

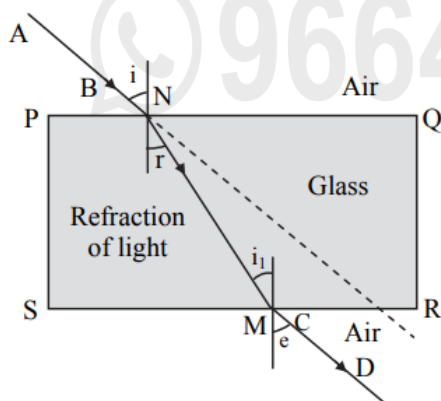

- (a) What is refraction of light?
- (b) Name the emergent ray.
- (c) Which two angles are equal?

Q.3. Answer the following questions (any five):

- i. Calculate the escape velocity on the surface of the moon given the mass and radius of the moon to be 7.34×10^{22} kg and 1.74×10^6 m respectively. (Given: $G = 6.67 \times 10^{-11}$ Nm²/kg²).
- ii. An element has its electron configuration as 2, 8, 1. Now answer the following questions:
 - (a) What is the atomic number of this element?
 - (b) What is the group of this element?
 - (c) To which period does the element belong?
- iii. Observe the figure and name the ray AB, ray CD, ray GH:

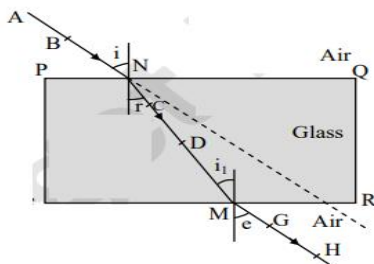

- iv. Read the following sentence and answer the questions:

“NaCl is an ionic compound.”

 - (a) Why is NaCl an ionic compound?
 - (b) State any two properties of ionic compounds.
- v. Identify the physical and chemical changes from the following phenomena:
 - (a) Transformation of ice into water.
 - (b) Ripening of fruit.
 - (c) Milk turned into curd.
 - (d) Evaporation of water.
 - (e) Digestion of food in the stomach.
 - (f) Iron filings get attracted towards the magnet.
- vi. Observe the following figure and answer the questions:

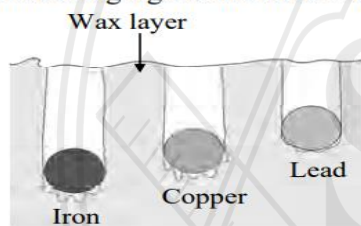

Specific heat capacity of metals

- (a) Which element has maximum specific heat capacity? Justify.
- (b) Which element has minimum specific heat capacity? Justify.
- (c) Define specific heat of object.

- vii. Identify figures A, B, C and given their uses:

(A)



(B)



(C)



- viii. Complete the following flow chart:

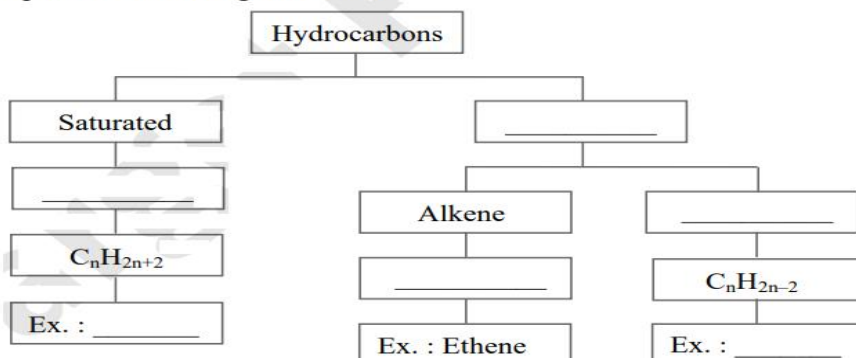

Q.3. Answer any five of the following questions:

i. Identify the phenomenon shown in the figure below. State and explain it :

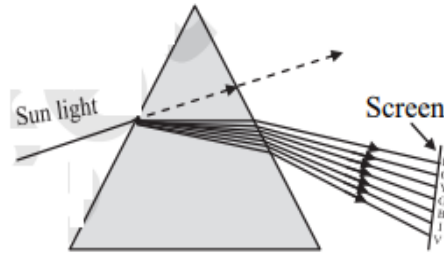

ii. Observe the following diagram and answer the questions given below :

- Identify the device shown in the figure.
- On which rule is the working of the above device based?
- Give any two uses of this device.

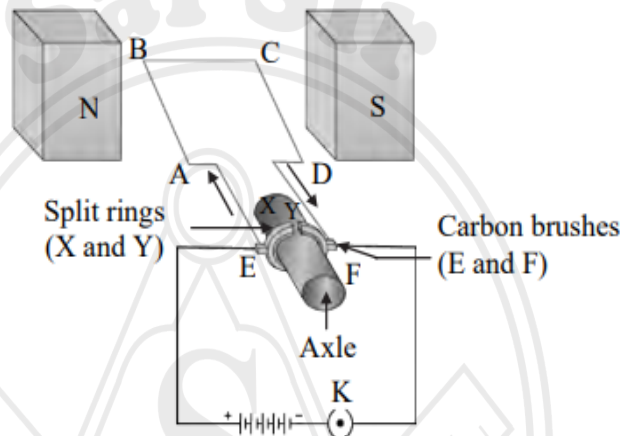

- The atomic number of nitrogen is 7. How many electrons are present in the valence shell of nitrogen?
 - Molecular formula of nitrogen is N_2 . Draw the electron-dot structure and line structure of a nitrogen molecule.
- The mass and weight of an object on the earth are 5 kg and 49 N respectively. What will be their values on the moon? Assume that the acceleration due to gravity on the moon is $1/6$ th of that of the earth.
- To which group does the halogen family belong? Write any four halogens.
- What is redox reaction? Explain with the help of a balanced chemical equation.
- Explain the following temperature vs. time graph :

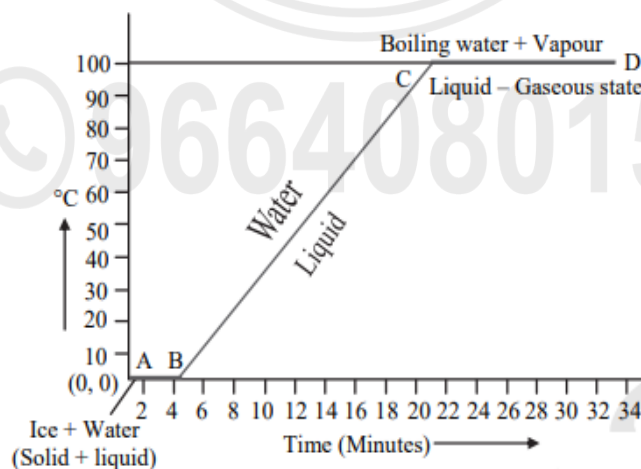

- An element has its electronic configuration as 2, 8, 2. Answer the following questions :
 - What is the atomic number of this element?
 - What is the group of this element?
 - To which period does this element belong?

Q.3. Answer the following (any five):

- i. Write the demerits of Mendeleev's periodic table.
- ii. State the laws related to the given diagram:

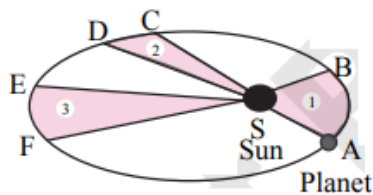

- iii. Identify the type of chemical reaction given below:

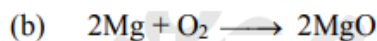
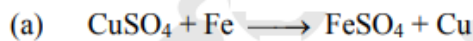

- iv. If the speed of light in a medium is 1.5×10^8 m/s, what is the absolute refractive index of the medium? (Speed of light in vacuum = 3×10^8 m/s).

- v. Read the following paragraph and answer the questions based on it:

If heat is exchanged between a hot and cold object, the temperature of the cold object goes on increasing due to gain of energy and the temperature of the hot object goes on decreasing due to loss of energy.

The change in temperature continues till the temperatures of both the objects attain the same value. In this process, the cold object gains heat energy and the hot object loses heat energy. If the system of both the objects is isolated from the environment by keeping it inside a heat resistant box, then no energy can flow from inside the box or come into the box.

- (a) Heat is transferred from where to where?
- (b) Which principle do we learn about from this process?
- (c) How will you state the principle briefly?

- vi. Complete the following table for convex lens:

Sr. No.	Position of the object	Position of the image	Nature of the image
1.	Beyond $2F_1$	_____	_____
2.	_____	At infinity	_____
3.	_____	_____	Real, inverted and enlarged

- vii. Explain the following terms:

- (a) Metallurgy
- (b) Ores
- (c) Gangue.

- viii. State the importance of Space Mission.

For More Such Study Material for standard 10th

Keep Visiting www.saiphy.com

If any of the study material is helpful for you

Kindly Send your review on

9664080155

Easy Notes By Sai Sir

Q.3. Answer the following (any five):

- i. An iron ball of mass 3 kg is released from a height of 125 m and falls freely to the ground. Assuming that the value of 'g' is 10 m/s², calculate:
- Time taken by the ball to reach the ground.
 - Velocity of the ball on reaching the ground.
- ii. An element has its electron configuration as (2, 8, 2). Answer the following:
- What is the 'atomic number' of this element?
 - What is the 'Group' of this element?
 - To which period does this element belong?
- iii. a. Write the 'endothermic' or 'exothermic' nature of the reaction:
- $$2\text{KClO}_{3(s)} \xrightarrow{\Delta} 2\text{KCl}_{(s)} + 3\text{O}_{2 \uparrow}$$
- b. Balance the given chemical equation:
- $$\text{NaOH}_{(aq)} + \text{H}_2\text{SO}_{4(aq)} \rightarrow \text{Na}_2\text{SO}_{4(aq)} + \text{H}_2\text{O}_{(l)}$$
- c. From given reaction, identify 'oxidant' and 'reductant':
- $$\text{CuO} + \text{H}_2 \rightarrow \text{Cu} + \text{H}_2\text{O}$$
- iv. A copper sphere of 100 g mass is heated to raise its temperature to 100°C and is released in water of mass 195 g and temperature 20°C in a copper calorimeter. If the mass of the calorimeter is 50 g, what will be the maximum temperature of water? (Specific heat of copper = 0.1 cal/g°C)
- v. a. Draw a neat labelled diagram of 'dispersion of white light through glass prism'.
- Which coloured ray is the least deviated?
 - Which coloured ray is the most deviated?
- vi. Complete the following table for convex lens:

	Position of object	Position of image	Size of image	Nature of image
(a)	_____	At focus F ₂	Point image	Real and inverted
(b)	At 2F ₁	At 2F ₂	_____	Real and inverted
(c)	Between F ₁ and O (within focal length)	On the same side (object side)	Very large	_____

- vii. Observe the following diagram and answer the questions:

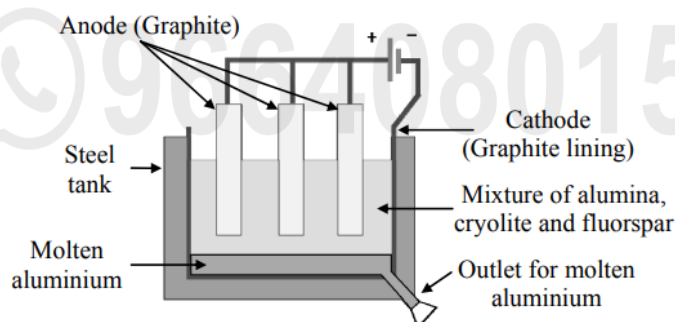

- Write the 'anode reaction'.
 - Write the 'cathode reaction'.
 - What is the purpose of mixing 'cryolite' and 'fluorspar' with 'alumina' in the electrolytic reduction of alumina?
- viii. a. What is the principle behind the working of satellite launch vehicle?
- Write the formula for the escape velocity.
 - Write the long form of 'ISRO'.

Q.3. Answer the following (any five):

[15]

- i. An element has its electronic configuration as 2, 8, 2. Now answer the following questions:
 - a. What is the atomic number of this element?
 - b. What is the group of this element?
 - c. To which period does this element belong?

- ii. Observe the given figure showing the orbit of a planet moving around the Sun and write the *three* laws related to it:

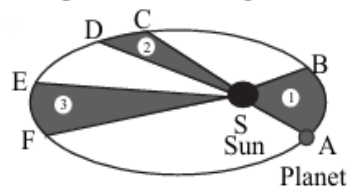

The orbit of a planet moving around the Sun

- iii. Read the given passage and answer the following questions:
 The home electrical connection consists of 'live', 'neutral' and 'earth' wires. The 'live' and the 'neutral' wires have potential difference of 220 V. The 'earth' is connected to ground. Due to a fault in the equipment or if the plastic coating on the 'live' and the 'neutral' wires gives a way the two wires come in contact with each other and a large current flows through it producing heat. If any inflammable material (such as wood, cloth, plastic, etc.) exists around that place it can catch fire. Therefore a fuse wire is used as a precautionary measure.
 - a. Name the two wires having potential difference of 220 V.
 - b. What is short circuit?
 - c. Write the function of a fuse.

- iv. Observe the given figure and answer the following questions:
 - a. Name the process represented by the figure.
 - b. State the two laws related to the process.

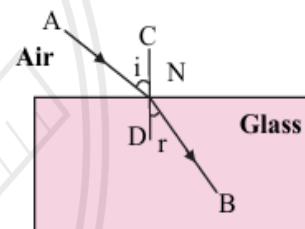

- v. What is an artificial satellite? Name any two types of artificial satellite and state their functions.
- vi. Answer the following questions:
 - a. Define Hydrocarbons.
 - b. Name the types of Hydrocarbons.
 - c. Name two carbon compounds used in day-to-day life.

9664080155

For More Such Study Material for standard 10th

Keep Visiting www.saiphy.com

If any of the study material is helpful for you

Kindly Send your review on

9664080155

Easy Notes By Sai Sir

vii. Observe the given figure of reactivity series of metals and answer the following questions:

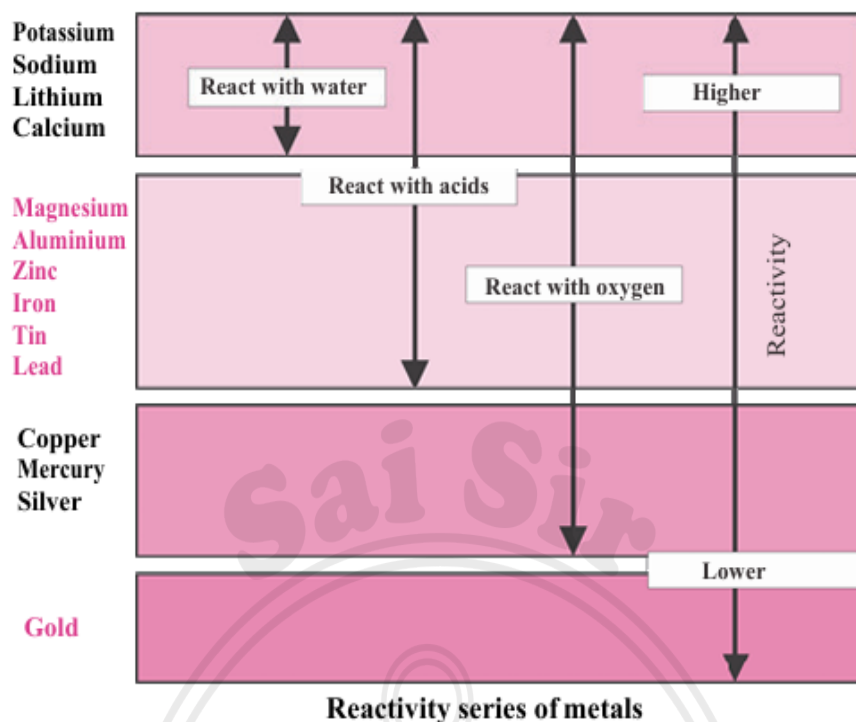

- Name two metals which react with water.
- Name two moderately reactive metals.
- Name the most highly reactive metal and the most less reactive metal.

viii. Complete the following table:

Straight chain of Carbon compounds	Structural formula	Molecular formula	Name
C	$\begin{array}{c} \text{H} \\ \\ \text{H} - \text{C} - \text{H} \\ \\ \text{H} \end{array}$	CH ₄	Methane
C-C	_____	_____	Ethane
C-C-C	_____	C ₃ H ₈	_____
C-C-C-C	$\begin{array}{cccc} \text{H} & \text{H} & \text{H} & \text{H} \\ & & & \\ \text{H} - \text{C} - & \text{C} - & \text{C} - & \text{C} - \text{H} \\ & & & \\ \text{H} & \text{H} & \text{H} & \text{H} \end{array}$	_____	_____

For More Such Study Material for standard 10th

Keep Visiting www.saiphy.com

If any of the study material is helpful for you

Kindly Send your review on

9664080155

Easy Notes By Sai Sir

Q.3. Solve the following questions (any five):

- i. An object thrown vertically upwards reaches a height of 500 m. What was its initial velocity? How long will the object take to come back to the earth? ($g = 10 \text{ m/s}^2$)
- ii. Explain the similarity and difference in two events namely adding NaOH to water and adding CaO to water.
- iii. Observe the following reaction carefully and answer the sub-questions:

$$\text{NH}_3 + \text{HCl} \longrightarrow \text{NH}_4\text{Cl}$$
 - a. What are the salt and acid in the above reaction?
 - b. Which is the base in the above reaction? It is weak or strong?
 - c. Write a reaction showing dissociation of this base in water.
- iv. Explain the following temperature Vs. time graph:

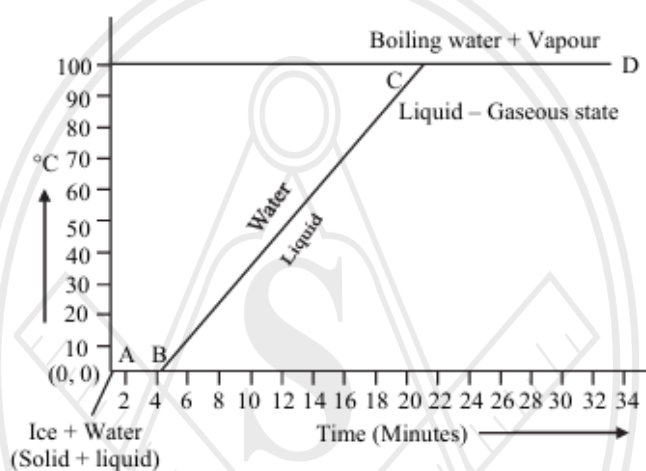

- v. Doctor has prescribed a lens having power +1.5 D for correction of eye defect. What will be the focal length of the lens? What is the type of the lens and what must be the defect of vision?
- vi. Give scientific reason:
Anodes need to be replaced from time to time during the electrolysis of alumina.
- vii. What is meant by Vinegar and Gashol? What are their uses?

For More Such Study Material for standard 10th

Keep Visiting www.saiphy.com

If any of the study material is helpful for you

Kindly Send your review on

9664080155

Easy Notes By Sai Sir

3. Attempt any five of the following questions:

1. What would be the value of 'g' on the surface of the earth if its mass was twice and its radius half of what it is now?
2. Write merits of Mendeleev's periodic table.
3. Study the following chemical reaction and answer the questions given below:

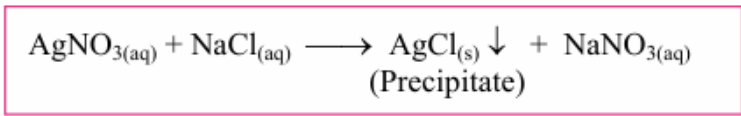

- i. Identify and write the type of chemical reaction.
 - ii. Write the definition of above type of chemical reaction.
 - iii. Write the names of reactants and products of above reaction.
4. Explain the following temperature Vs time graph:

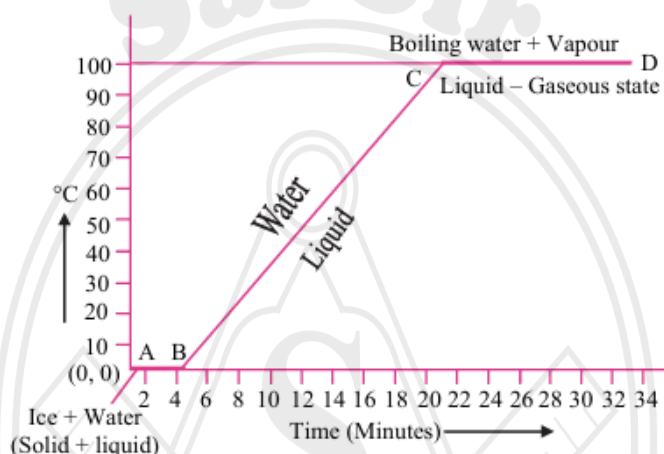

5. Surabhi from std. X uses spectacle. The power of the lenses in her spectacle is 0.5 D. Answer the following questions from the given information:
- i. Identify the type of lenses used in her spectacle.
 - ii. Identify the defect of vision Surabhi is suffering from.
 - iii. Find the focal length of the lenses used in her spectacle.

6. Complete the following table:

Sr. No.	Common Name	Structural Formula	IUPAC Name
1.	Ethylene	$\text{CH}_2 = \text{CH}_2$
2.	CH_3COOH	Ethanoic acid
3.	Methyl alcohol	Methanol

7. What is meant by space debris? Why there is need to manage the debris?

For More Such Study Material for standard 10th

Keep Visiting www.saiphy.com

If any of the study material is helpful for you

Kindly Send your review on

9664080155

Easy Notes By Sai Sir

Q.4. Answer the following (any one):

[5]

- i. "A rainbow is the combined effect of the refraction, dispersion and total internal reflection of light." Prove this statement with the help of diagram and explain it.
- ii. Complete the following table:

Sr. No.	Straight chain of carbon atoms	Molecular formula	Name
1.	C	CH ₄	_____
2.	C-C	_____	Ethane
3.	C-C-C	C ₃ H ₈	_____
4.	C-C-C-C	_____	Butane
5.	C-C-C-C-C	C ₅ H ₁₂	_____
6.	C-C-C-C-C-C	_____	Hexane
7.	C-C-C-C-C-C-C	_____	Heptane
8.	C-C-C-C-C-C-C-C	C ₈ H ₁₈	_____
9.	C-C-C-C-C-C-C-C-C	_____	Nonane
10.	C-C-C-C-C-C-C-C-C-C	_____	Decane

March 2025 Q.4 Answer the following questions

Q.4. Answer any one of the following:

[5]

- i.
 - (a) Draw a neat labelled diagram of human eye.
 - (b) What is the minimum distance of distinct vision for a normal human eye?
 - (c) Name the capacity of the eye lens to change its focal length as per need.
 - (d) Name the defect of eye vision in which the focussing power of eye lens decreases with age.
- ii. Atomic number of chlorine is 17.
 - (a) Write the electronic configuration of chlorine.
 - (b) What is the number of electrons in the valence shell of chlorine?
 - (c) Write the molecular formula of chlorine.
 - (d) Name the type of bond in the formation of chlorine molecule.
 - (e) Draw the electron dot structure of a chlorine molecule.

9664080155

For More Such Study Material for standard 10th

Keep Visiting www.saiphy.com

If any of the study material is helpful for you

Kindly Send your review on

9664080155

Easy Notes By Sai Sir

Q.4. Answer the following questions (any one):

[5]

- i. Observe the given diagram and answer the questions :

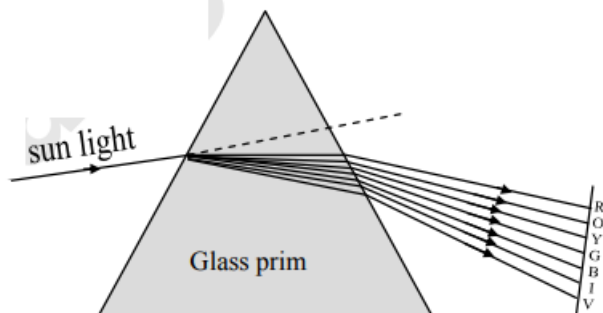

- (a) Name the process shown in the figure.
(b) Name the colour that deviates the most.
(c) Name the colour that deviates the least.
(d) Name any *one* phenomenon in the nature which is based on the above process.
(e) Define 'spectrum'.
- ii. Observe the diagram given below and answer the questions :

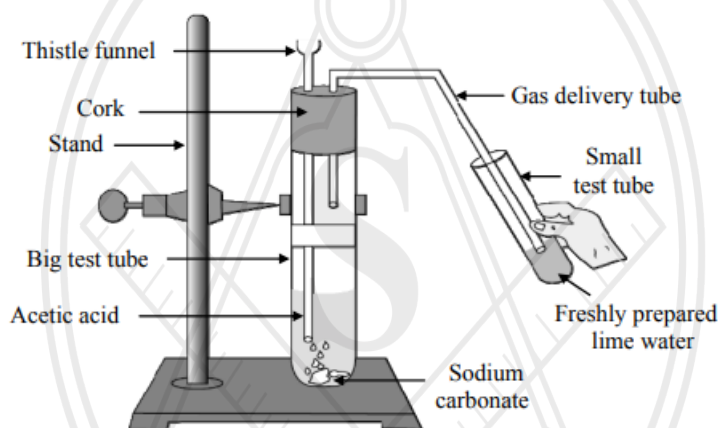

- (a) Name the reactants in this reaction.
(b) Which gas comes out as effervescence in the bigger test tube?
(c) What is the colour change in the lime water?
(d) In the above experiment instead of sodium carbonate which chemical can be used to get same product?
(e) Write the use of acetic acid.

9664080155

For More Such Study Material for standard 10th

Keep Visiting www.saiphy.com

If any of the study material is helpful for you

Kindly Send your review on

9664080155

Easy Notes By Sai Sir

Q.4. Attempt any one of the following questions:

- i. Observe the given diagram and answer the following questions:

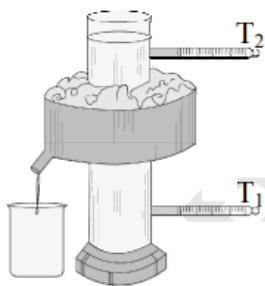

- (a) What is the name of the given apparatus?
 (b) Which phenomenon is studied with the help of this apparatus?
 (c) What are the final temperatures in thermometers T_1 and T_2 ?
 (d) At what temperature the density of water is maximum?
 (e) Give *one* example of the above phenomenon in nature.
- ii. Observe and write the answers to the questions given below:

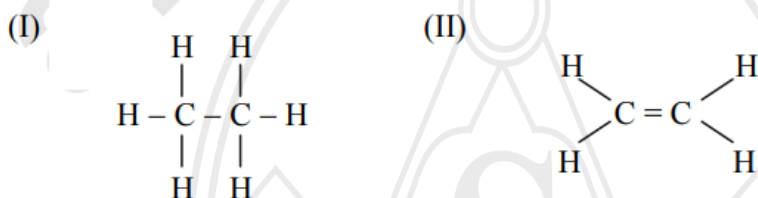

- (a) Write the names of compound I and II.
 (b) Draw electron-dot structure for I and II.
 (c) Which one of the above structures is saturated compound and unsaturated compound?

March 2023 Q.4 Answer the following questions**Q.4. Answer any one of the following questions:**

[5]

- i. Observe the figure and answer the following questions:

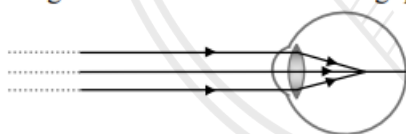

- (a) Name the defect of vision represented in above figure.
 (b) State the reasons for this defect.
 (c) How is it corrected?
 (d) Draw the diagram to show the correction of this defect.
- ii. Complete the following table:

S.N.	Common Name	Structural Formula	IUPAC Name
1.	Ethylene	$\text{CH}_2 = \text{CH}_2$	
2.	Acetylene		Ethyne
3.	Acetic acid	$\text{CH}_3 - \text{COOH}$	
4.	Methyl alcohol		Methanol
5.		$\text{CH}_3 - \text{CO} - \text{CH}_3$	Propane-2-one

Q.4. Attempt any one of the following questions:

[5]

- i.
 - a. What is the minimum distance of distinct vision for normal human eye?
 - b. Identify the defect of vision shown in the figure :

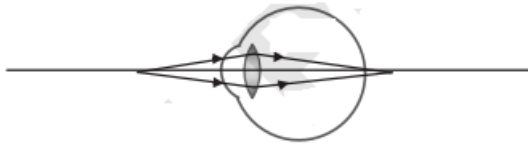

- c. Focal length of a convex lens is 25 cm. What is its power?
 - d. Define power of a lens.
 - ii. State the general properties of ionic compounds.

March 2022 Q.4 Answer the following questions

Q.4. Answer any one of the following questions:

[5]

- i. Observe the following diagram and answer the questions given below:

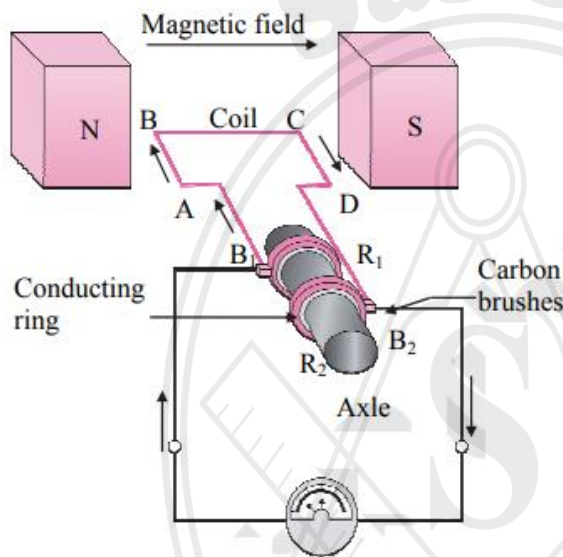

- a. Identify the above diagram. 1
 - b. Write the principle on which the above appliance works. 1
 - c. Write the working of the above appliance. 2
 - d. Write the use of the above appliance. 1
- ii.
 - a. Identify saturated and unsaturated hydrocarbon from the given structural formula: 2

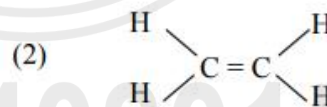
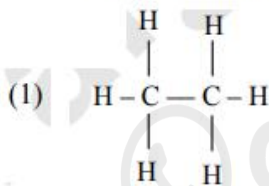

- b. Draw electron dot structure for (1) and (2). 2
 - c. Define Homologous series. 1

For More Such Study Material for standard 10th

Keep Visiting www.saiphy.com

If any of the study material is helpful for you

Kindly Send your review on

9664080155

Easy Notes By Sai Sir

Q.4. Solve the following questions (any one):

[5]

i. Observe the diagrams and answer the questions:

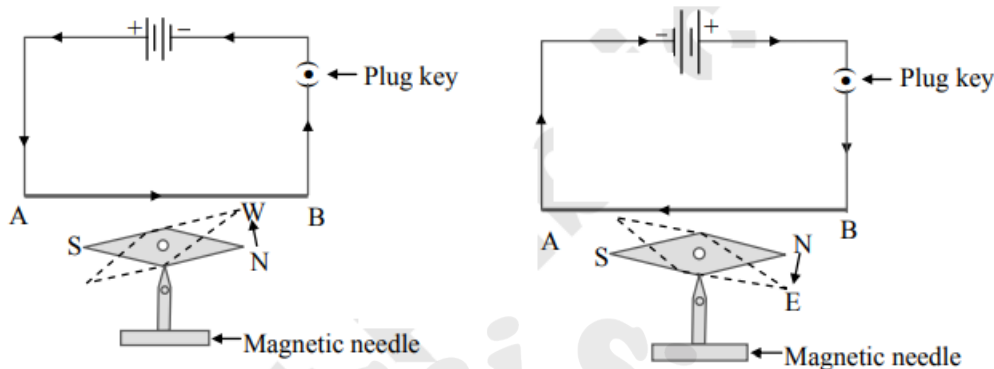

- Which effect of electric current is shown in the above figure?
- What will happen if the number of electric cells is increased on the magnetic needle?
- If the distance between the conductor and magnetic needle is increased, what will be the effect on intensity of magnetic field?
- If the ends of electric cell are interchanged, what will be the effect of the magnetic needle?
- Write the names of any *two* instruments which work on magnetic effect of electric current.

ii. Answer the following:

- Draw the electron-dot structure of Methane.
- Define Homologous series.
- Write the IUPAC names of the following:
 - $\text{CH}_3 - \text{CH}_2 - \text{COOH}$
 - $\text{CH}_3 - \text{CHOH} - \text{CH}_3$
 - $\text{CH}_3 - \text{CO} - \text{CH}_2 - \text{CH}_3$

March 2020 Q.4 Answer the following questions

Q.4. Answer any one of the following:

[5]

- Draw a scientifically correct labelled diagram of a human eye and answer the questions based on it:
 - Name the type of lens in the human eye.
 - Name the screen at which the maximum amount of incident light is refracted?
 - State the nature of the image formed of the object on the screen inside the eye.
- Observe the following picture and answer the following questions:
 - What is a rust?
 - Write the chemical formula of rust.
 - Write the reaction of oxidation of iron at anode.
 - Write the reaction of oxidation of iron at cathode.
 - What is corrosion?

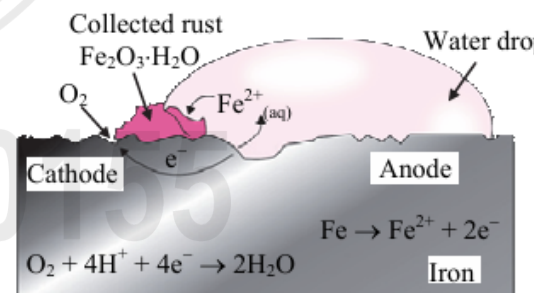

For More Such Study Material for standard 10th

Keep Visiting www.saiphy.com

If any of the study material is helpful for you

Kindly Send your review on

9664080155

Easy Notes By Sai Sir

Q.4. Solve the following questions (any one):

[5]

i. Observe the following diagram and write the answers of the following questions:

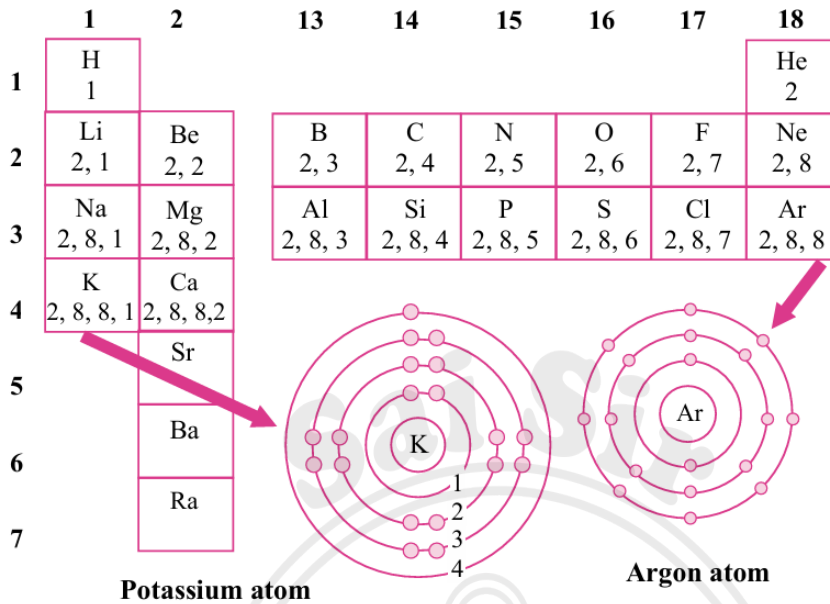

- Write the atomic numbers of first two elements in the second group.
- Write the number of valence electrons of the elements in the halogen group.
- Draw the diagram of electronic configuration of magnesium atom.
- After completion of a period, what change does take place in the electronic configuration of the next element?
- Write the names of any two elements from the diagram which do not take part in chemical reaction.

ii. Observe the following diagram and write the answers of the given sub-questions:

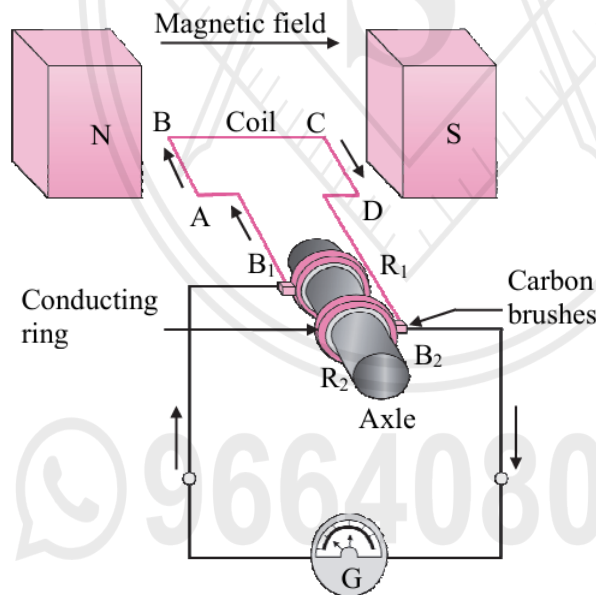

- Which instrument the above figure shows?
- Which rule is used to determine the direction of the current produced?
- State the rule.
- In which direction (B_1 to B_2 or B_2 to B_1) will the current flow in the external circuit in that situation?
- What change will have to be made in the coil for increasing the current several times without changing the magnet?

Q.4. Answer any *one* of the following questions:

[5]

1. Taking into consideration the period of the elements given below, answer the following questions:

Elements	Atomic Radius (pm)
O	66
B	88
C	77
N	74
Be	111
Li	152

- Arrange the above elements in a decreasing order of their atomic radii.
 - State the period to which the above elements belong.
 - Why this arrangement of elements is similar to the above period of modern periodic table?
 - Which of the above elements have the biggest and the smallest atom?
 - What is the periodic trend observed in the variation of atomic radius while going from left to right within a period?
2. The observation made by Swarali while doing the experiment are given below. Based on these write answers to the questions:
Swarali found that the light ray travelling from the denser medium to rarer medium goes away from the normal. If the angle of incidence (i) is raised by Swarali, the angle of refraction (r) went on increasing. However after certain value of the angle of incidence the light ray is seen to return back into the denser medium.
- Questions:
- What is the specific value of i called?
 - What is the process of reflection of incident ray into denser medium called?
 - Draw the diagrams of three observations made by Swarali.

**For More Such Study Material for standard 10th
Keep Visiting www.saiphy.com**

**If any of the study material is helpful for you
Kindly Send your review on
9664080155**

Easy Notes By Sai Sir